

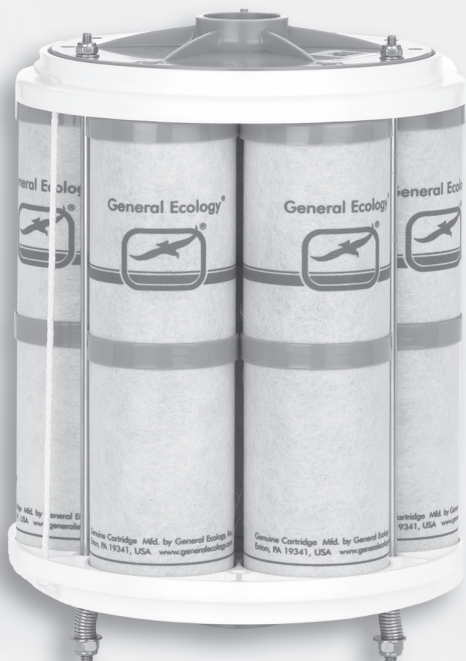

# SPARK-L-PURE®

## *INSTALLATION AND PRODUCT USE GUIDE*

### WATER MICROFILTRATION SYSTEM



### Installation Instructions

CONGRATULATIONS! You have just purchased SPARK-L-PURE® Water Microfiltration System by General Ecology, Inc. employing the most advanced, effective and reliable technology available. The features of this equipment are indicated in product literature accompanying each System. It is recommended that you briefly study this literature before beginning your installation. Please note that the SPARK-L-PURE® Unit features Top Mounted, NPT threaded ports that are available in either  $\frac{3}{4}$  or 1 inch sizes. Be sure you have the proper size for your installation (normally  $\frac{3}{4}$  inch for residential applications).

Multiple Units can be installed in parallel to increase flow rate (for industrial, commercial and special applications), or in series for special requirements such as pre-filtration followed by sub micron microfiltration. See Figure 1. Not for sale in Wisconsin. Not for residential sale in California.

Installation is straightforward and is easily accomplished by persons experienced in plumbing installation. A  $\frac{1}{2}$ " "deep" socket, in lieu of the wrench, will facilitate V-clamp Nut removal and replacement and is recommended.

For use with Microbiologically Safe Water Only.

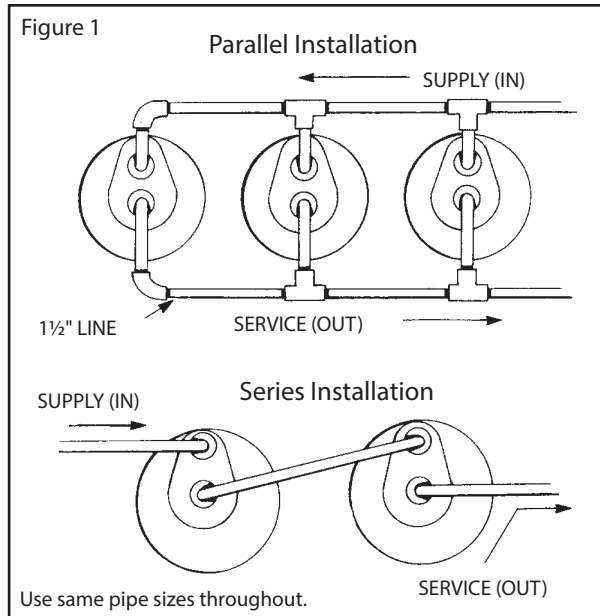

## Assembly Instructions

1. Remove the stainless steel Housing and the Cartridge Module from the package.
2. Remove the V-Clamp that secures the Housing Cover and Bowl by removing ½" Nut with a wrench or ½" deep socket.
3. Carefully raise the Cover, being careful not to dent or cut the Bowl Flange, nor allow dirt on any of the Gaskets.
4. Lower the Cartridge Module into the Bowl.
5. Be sure Gaskets are clean and free of cuts and other potential leak paths.
6. For ease of installation, a light coating of petroleum jelly should be applied to center Port O-Rings of Housing Cover before aligning it with the Cartridge Module.
7. Center the Cover on the Module while aligning it with the Bowl Flange and press down into position.
8. Install V-clamp and tighten (do not overtighten) while lightly tapping the outside of the V-clamp outside the bolt. A light coating of petroleum jelly applied to the insides of the V-clamp segments will ease the Clamp installation.
9. Note the Unit Cover's Supply (INLET) Port and Service (OUTLET) Port. On all General Ecology stainless steel Units the Port closest to the side is the Supply (INLET) Port and the center Port is the Service (OUTLET) Port.

## Equipment Placement

The SPARK-L-PURE® Unit should be level and should have adequate vertical clearance to permit the three (3) Dielectric Positioning Pads to be positioned under each Unit. It is important to use these Pads to allow vertical clearance for the Unit to clear the Inlet and Outlet Connectors during servicing. Additionally, the Pads eliminate potential electrical interface between the Unit and the floor.

Installation with flexible lines will allow easy positioning of unit and facilitate future servicing.

The Unit should always be placed on the Service (OUTLET) side, rather than the Supply (INLET) side, of the air pressure tanks used with on-site water supplies. See Figure 2.

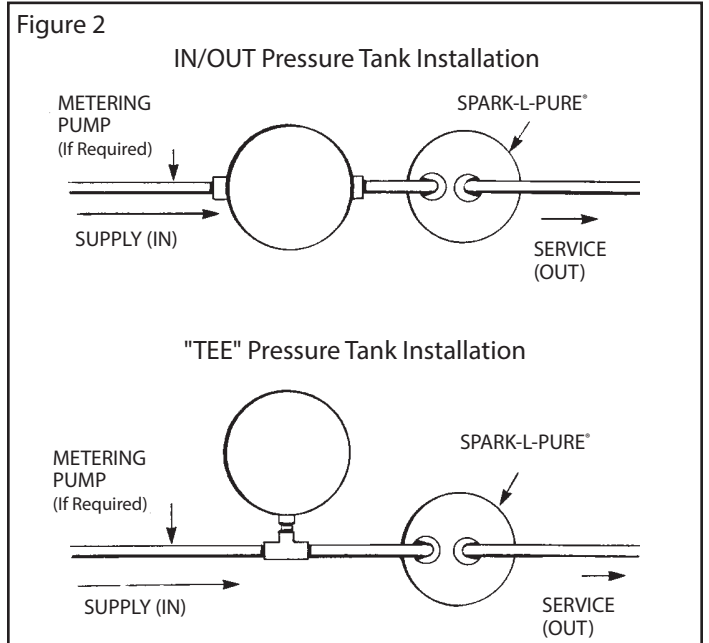

## SPARK-L-PURE® Parts List and Dimensions

No.	Description	Qty.	Part No.
1	Cover with NPT ports	1	N/A
2	Bowl	1	100300
3	V-Clamp	1	100400
4	Housing Gasket	1	100455
5	Module Outlet Port (center) Seal O-Rings (Internal)	2	100414
6	Dielectric Positioning Pads	3	100421
7	V-Clamp Hex Nut	1	100402
8	Aqua-Polish 7 Module	1	100500

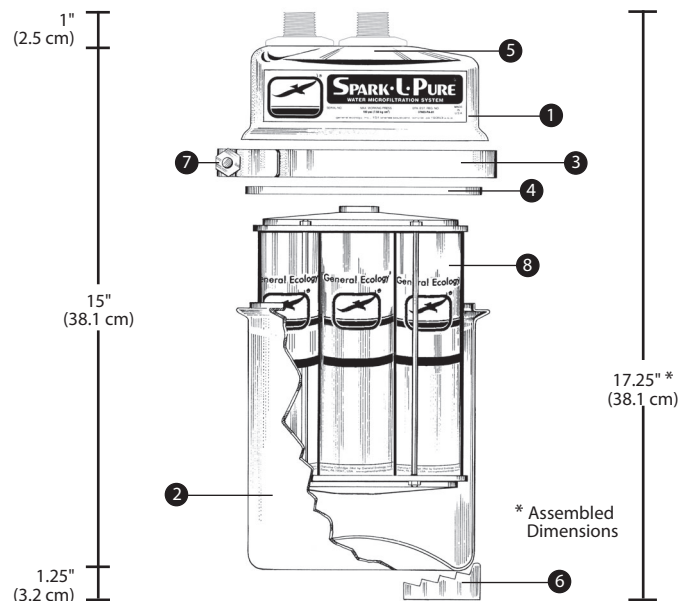

## Installation Considerations

Valves should be placed in series with the Supply (INLET) and Service (OUTLET) Lines as shown in Figure 3. A Flow Controller, if necessary, should be placed in the Supply Line to help limit flow surges due to trapped air and other possible causes. A Check Valve should be placed in the Service Line to protect the Unit from back pressure surges.

A By-pass Valve should be installed the Inlet and Outlet Lines. The by-pass valve can be opened to allow an uninterrupted water supply while the system is being serviced.

The SPARK-L-PURE® Unit is relatively compact, and is easily disconnected from the plumbing lines. It is not necessary to service the Unit in place; for convenience, it can be carried to a nearby sink, floor drain, or even outside. Adequate clearance should be provided around the installed Unit for ease of movement and to allow servicing on other pieces of equipment when necessary. Obviously, the Unit should not be allowed to freeze.

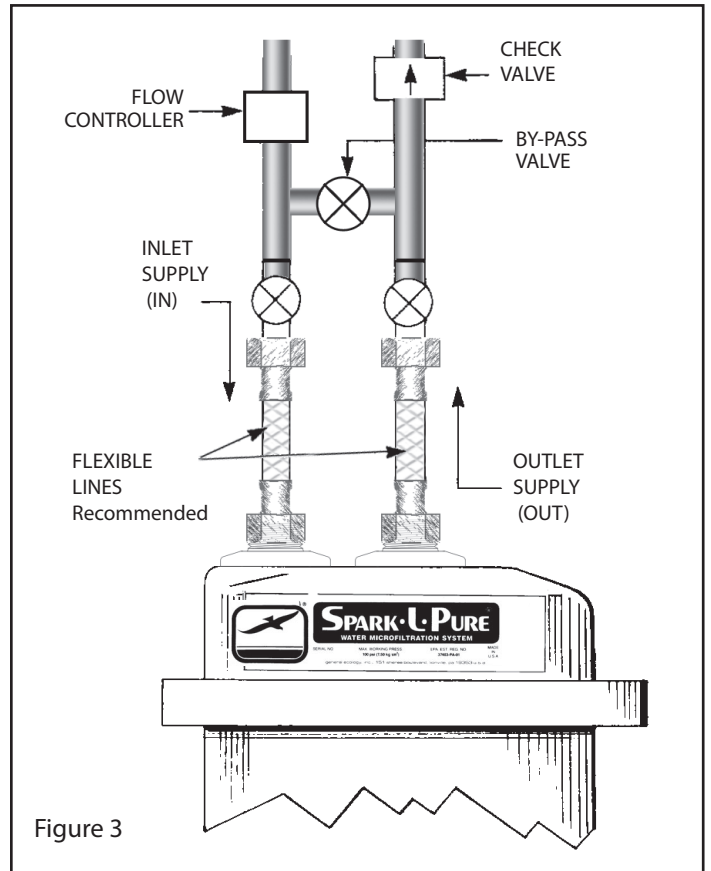

Figure 3

## Installation Instructions

1. Select location and position Unit as desired.
2. Close Supply and Service Valves to isolate the plumbing at the installation point.
3. Dry-fit the plumbing fittings and pieces necessary to install the Unit and cut or unthread existing plumbing lines as appropriate.
4. Connect all joints where applicable. Do not allow excess heat to reach any seals or gaskets and be sure solder does not reach the ball or seal of any valves.
5. In order to avoid the possibility of connecting the SPARK-L-PURE® Unit in the reverse direction, be sure to label the Supply (INLET) and Service (OUTLET) pipes.
6. Flush plumbing lines to remove any construction debris. Close By-pass valve.
7. Position the SPARK-L-PURE® Unit, and start the threads of the Closure Nuts. Place the Positioning Pads underneath the Unit and raise it to the proper elevation to eliminate strain on the Inlet and Outlet Ports, and only tighten the Inlet Port Nut at this time.
8. Slowly open the Supply Line Valve allowing water to enter the Unit. Trapped air will exhaust through the loosely connected Outlet Port until the Unit fills. When water starts to flow from the Outlet:
  - a. Close the Inlet Valve.
  - b. Snugly tighten the Outlet Closure Nut.
  - c. Open the Outlet Valve.
  - d. Reopen the Inlet Valve to place the SPARK-L-PURE® Unit in service.
9. Check carefully for leaks or seepage around any of the joints or connections and correct as necessary.
10. Allow water to run for three to five minutes to remove air and particles from new module.

### QUESTIONS?

Call 1-800-441-8166  
in USA/Canada  
for Customer Service

## Service Instructions

The SPARK-L-PURE® Microfiltration Unit, furnished with General Ecology, Inc.'s AQUA-POLISH® Cartridge Module requires little or no service other than occasional Module replacement. The need for changing the Module will be apparent from an obviously reduced flow rate due to clogging. Service should be accomplished by the following procedure.

**IMPORTANT:** In order to avoid reinstalling the Unit in the reverse direction, the Inlet and Outlet Pipes should be labeled prior to disconnecting the Unit. On all General Ecology® stainless steel Pressure Vessels, the Port closest to the Vessel Cover's side is the Supply (INLET) Port and the center Port is the Service (OUTLET) Port.

### Disassembly:

#### Removing Module from Unit:

1. Close Supply, open downstream valve or faucet to relieve pressure, then close service line valves. Loosen Closure Nuts and gradually remove Dielectric Positioning Pads to lower Unit to supporting surface.
2. Place Unit over drain or a container to catch excess water as the V-clamp is removed, and remove V-clamp.
3. Carefully raise the Cover from the Unit and remove the Cartridge Module. (The use of rubber gloves is recommended to protect the skin from contact with potential impurities that may be on the outside of the Module.) Dump excess water from the Bowl and rinse clean. Be careful not to dent or cut the Bowl Flange, nor cut nor allow dirt on any of the Gaskets.
4. For older SPARK-L-PURE® Systems only (prior to 1991): Check to be sure the Rubber Pedestal is properly in place on the raised center of the Bowl bottom when positioning the Module. Not required on Units purchased in 1991 or later.
5. Be sure Gaskets are clean and free of cuts and other potential leak paths.
6. For ease of installation look inside of cover for center port O-rings and apply a light coating of petroleum jelly before aligning and re-inserting the cartridge module.
7. Center the Cover on the Module while aligning it with the Bowl Flange and press down into position.
8. Install V-clamp and tighten (do not overtighten) while lightly tapping the outside of the V-clamp (not on the bolt). A light coating of petroleum jelly applied to the insides of the V-clamp segments will ease clamp installation.

### QUESTIONS?

Call 1-800-441-8166  
in USA/Canada  
for Customer Service

AS9100, ISO 9001 and FAA Quality Certified  
Original Equipment and PMA Manufacturer

(610)363-7900 - fax (610)363-0412  
www.generalecology.com

### Reinstallation:

#### Placing the Unit back in service:

1. Reposition the Unit per initial installation, being careful to properly position the Unit to eliminate strain on the Service and Supply Lines. Only tighten the Inlet Port Nut at this time.
2. Slowly open the Supply Line Valve allowing water to enter the Unit. Trapped air will exhaust through the loosely connected Outlet Port until the Unit fills. When water starts to flow from the Outlet:
  - a. Close the Inlet Valve.
  - b. Snugly tighten the Outlet Closure Nut.
  - c. Open the Outlet Valve.
  - d. Reopen the Inlet Valve to place the SPARK-L-PURE® Unit in service.
3. Allow water to run for three to five minutes to remove air and particles from the new module.

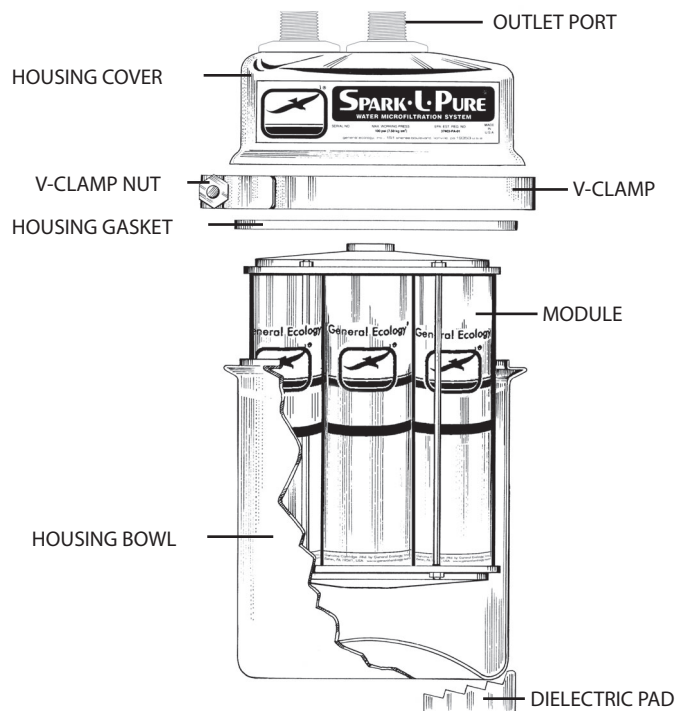

General Ecology, Inc.

the pure science of safe water™



151 Sheree Blvd., Exton, Pennsylvania 19341 USA